

KOLPA·SAN®

by KOLPA

- SI** Montažno navodilo
- HR** Upute za montažu
- BIH** Upute za montažu
- SRB** Uputstva za montažu
- BIH** Uputstva za montažu
- CG** Uputstva za montažu
- MK** Инструкцији за монтажа
- HU** Szerelési utasítás
- GB** Assembly instructions
- DE** Einbauleitungen
- RU** Инструкция по монтажу
- FR** Instruction d'assemblage

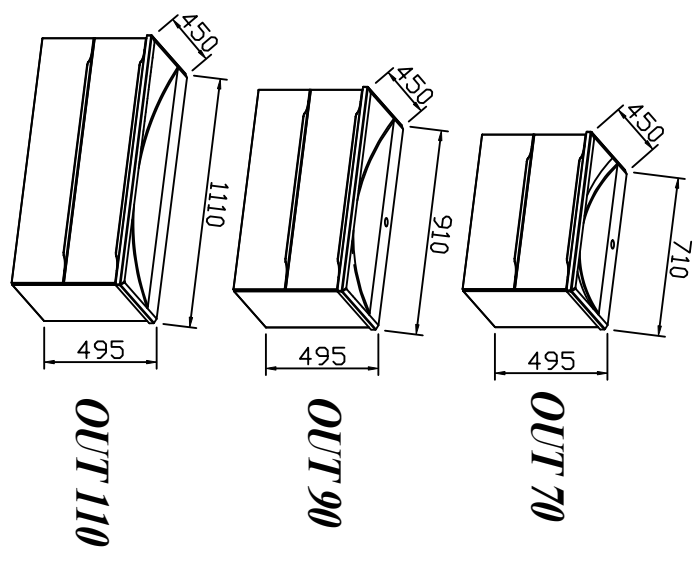

Tip: TARA - OUT 70, 90, 110

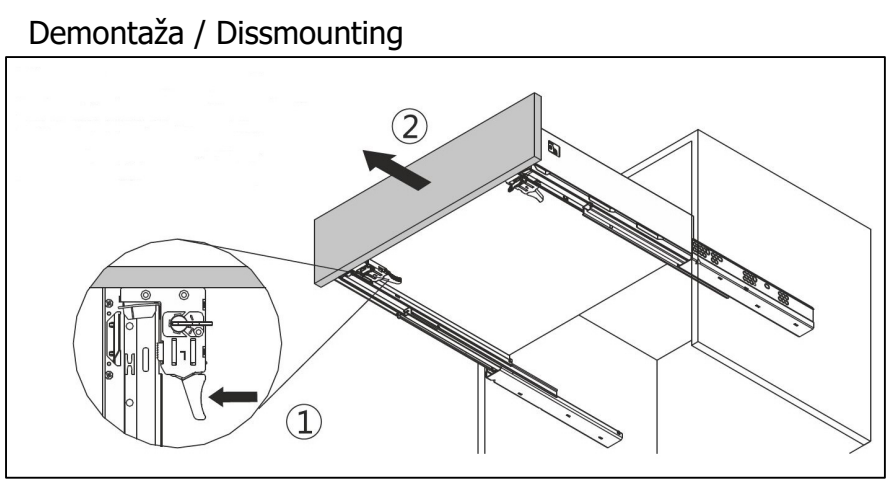
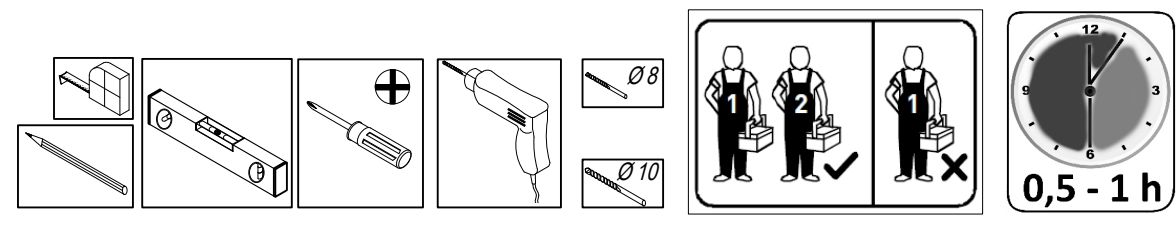
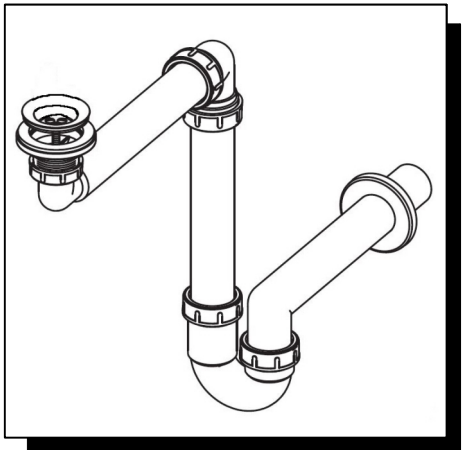
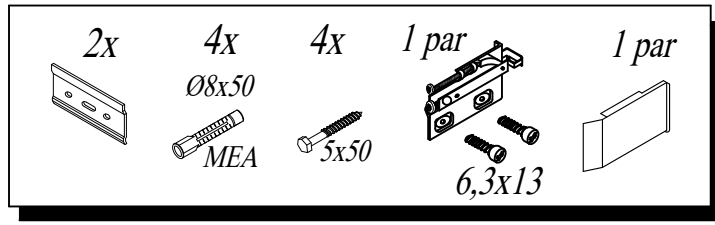

2

a)

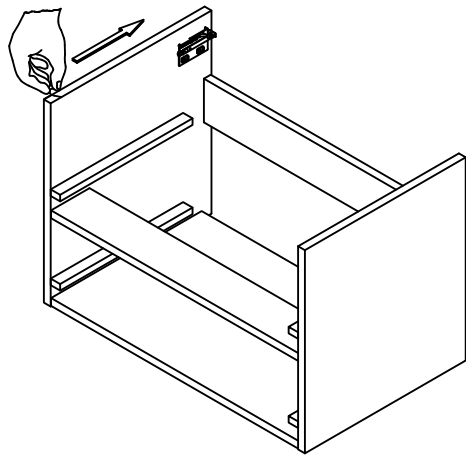

b)

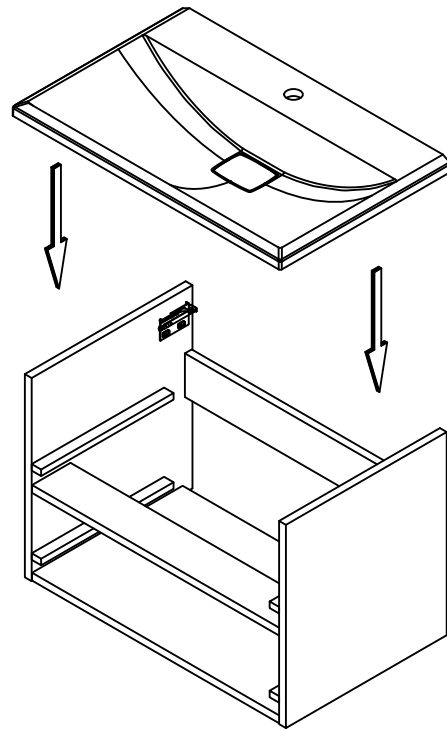

c)

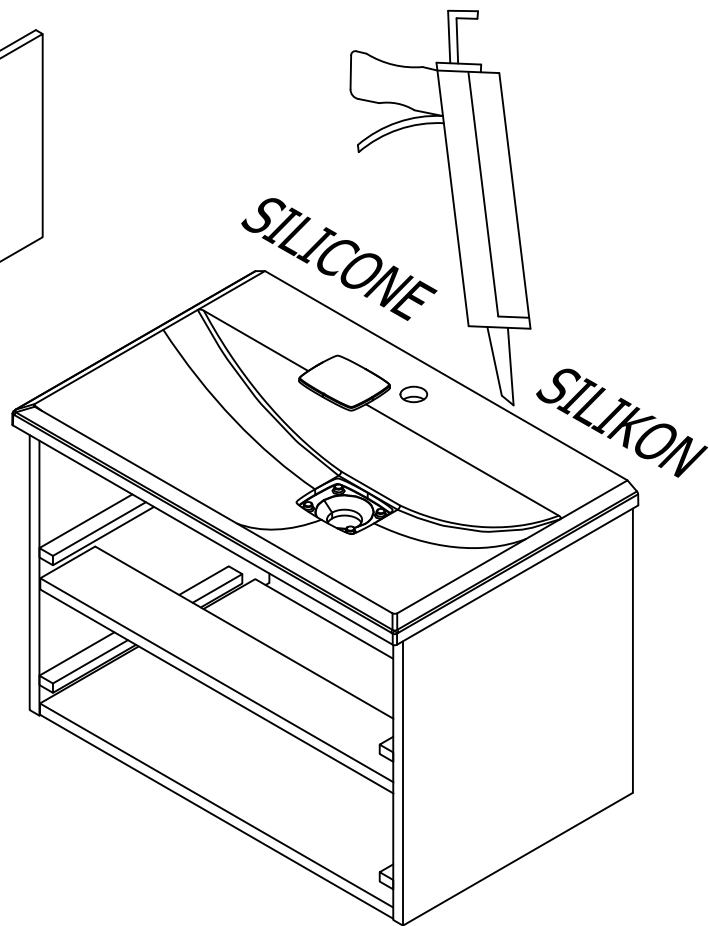

3

a)

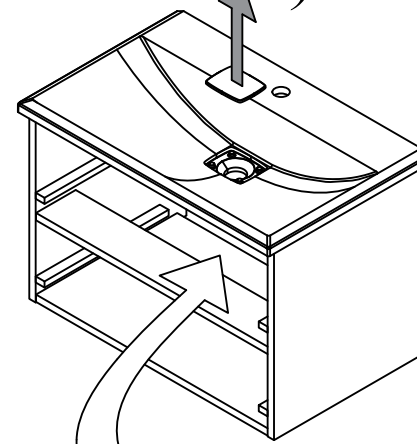

b)

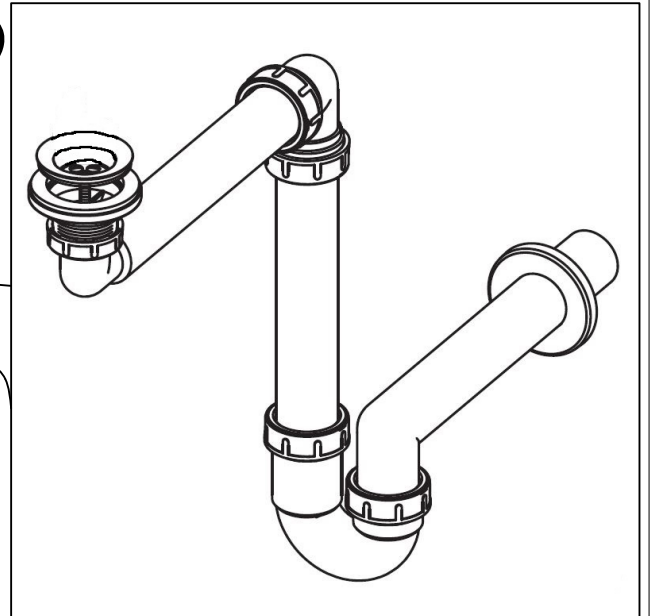

c)

Montaža / Mounting

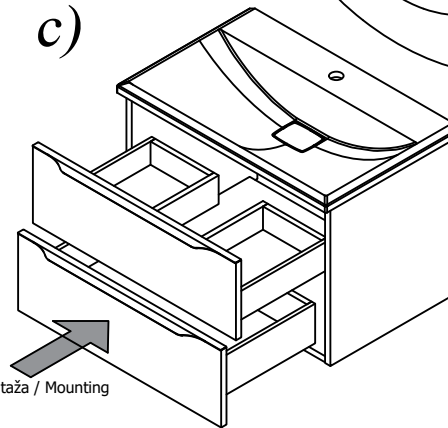

Nastavitve / Adjustment

Montaža / Mounting

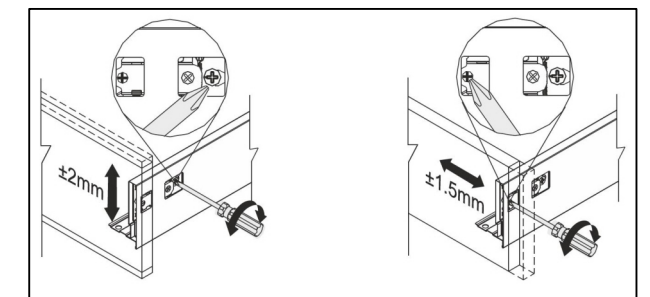
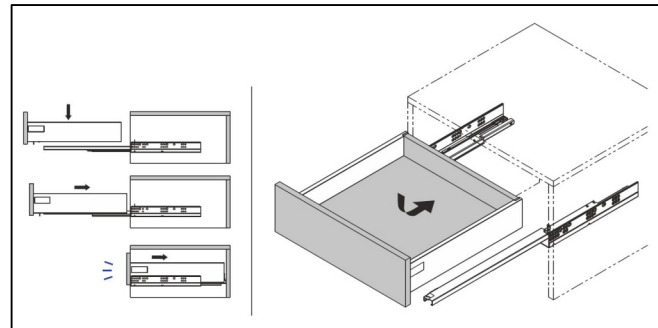

Odstranitev fronte / Removing of the front

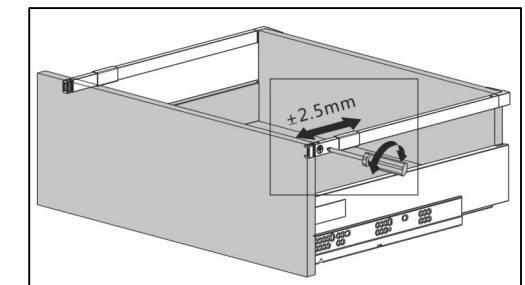
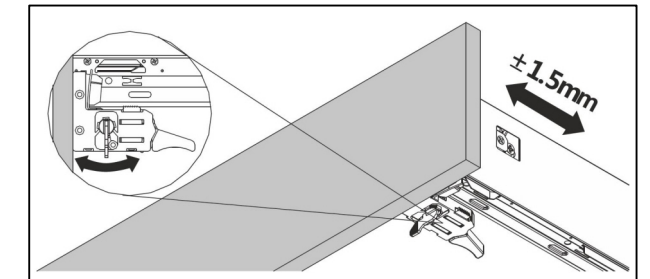
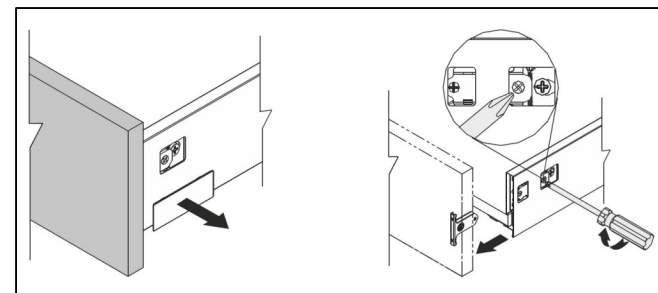

Kolpa-san®

by KOLPA

- SI** Montažno navodilo
- HR** Upute za montažu
- BIH** Upute za montažu
- SRB** Uputstva za montažu
- BIH** Uputstva za montažu
- CG** Uputstva za montažu
- MK** Нструкции за монтажа
- HU** Szerelési utasítás
- GB** Assembly Instructions
- DE** Einbauanleitung
- RU** Инструкция по монтажу
- FR** Instruction d'assemblage

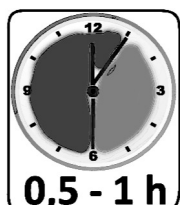
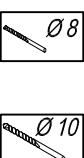
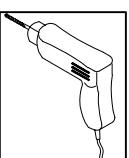
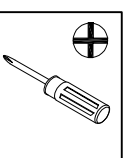
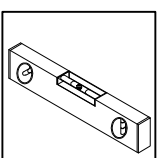
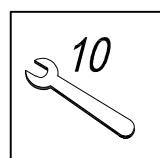
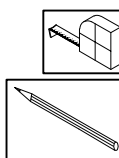
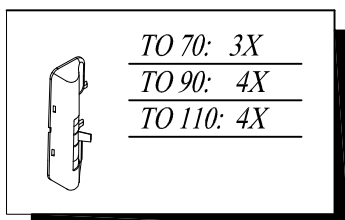
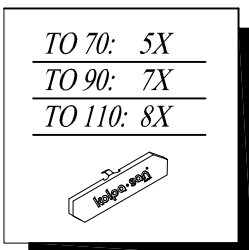
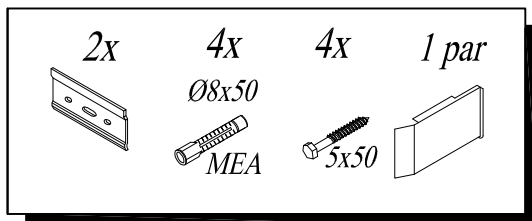
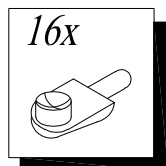
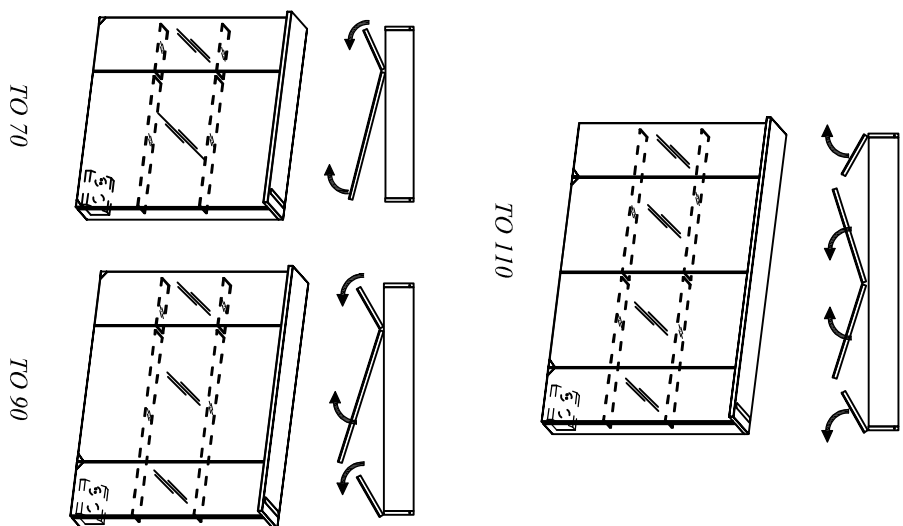

SLO: OPOZORILO:

- svetiljka mora biti oddaljena od kopalne kadi, tuš kadi ali izvora pršenja vode min. 0,6m (cona3)
- inštalacijo, priklop in menjavo mora izvesti usposobljena strokovna oseba
- svetlobni vir v tej svetilki lahko zamenja samo proizvajalec/njegov servisni zastopnik ali druga ustrezno usposobljena oseba
- če je zunanji prilagodljivi kabel te svetilke poškodovan, ga lahko zamenja izključno proizvajalec ali njegov servisni zastopnik ali podobna kvalificirana oseba, de se prepreči nevarnost

HR: UPOZORENJE:

- svjetiljka mora biti udaljena od kupaće kade, tuš kade ili izvora prskanja vode min. 0,6m (područ.3)
- instalaciju, uključenje i zamjenu smije obavljati osposobljena stručna osoba
- izvor svjetlosti koji se nalazi u ovom rasvjetnom tijelu smiju mijenjati samo proizvođač ili njegov serviser ili slična kvalificirana osoba
- ako su vanjski fleksibilni kabel ili žica ove svjetiljke oštećeni, može ih zamijeniti isključivo proizvođač ili njegov serviser ili slična kvalificirana osoba da bi se izbjegla opasnost

SRB: UPOZORENJE:

- CG:** - sijalica mora biti udaljena od kade za kupanje, tuša ili izvora prskanja vode min. 0,6m (zona3)
- BIH:** - instalaciju, priključak i zamenu mora obaviti osposobljeno stručno lice
- izvor svetlosti koju odaje ova lampa može da zameni samo proizvođač, ovlašćeni serviser ili kvalifikovano osoblje
- ukoliko su spoljašnji savitljiv kabl ili žica ove lampe oštećeni, mora da ga zameni isključivo proizvođač ili njegov zastupnik ili slično kvalifikovano lice da bi se izbegla opasnost.

HU: FIGYELMEZTETÉS:

- a lámpa legalább 0,6 méterre (3-as zóna) legyen a fürdőkádtól, zuhanyzókádtól, illetve az egyéb vízforrásoktól
- a lámpa beszerelését, hálózatra való csatlakoztatását, illetve cseréjét képzett szakmai személy végezze el
- e világítótest fényforrását kizárólag gyártója vagy hivatalos szervize vagy hasonló hozzáértő személy cserélheti.
- ha sértült e lámpatest hajlékony kábele vagy vezetéke, azt az áramtűzveszély megelőzése érdekében kizárólag a gyártó vagy márkaszervize vagy hasonló szakember cserélheti ki

GB: WARNINGS:

- The light must be at least 0,6m (zone 3) away from the bath tub or the source of water drizzle.
- Installation, connection and change must be performed by a qualified person.
- The light source contained in this luminaire shall only be replaced by the manufacturer or his service agent or a similar qualified person
- if the external flexible cable or cord of this luminaire is damaged, it shall be exclusively replaced by the manufacturer or his service agent or a similar qualified person in order to avoid a hazard

DE: HINWEIS:

- Lampen müssen von der Badewanne, Tuschkabine oder der Quelle des Wasserstrahles minimal 0,6m (Zone3) entfernt sein
- Die Installation, Anschluss und Umtausch darf nur eine befähigte Fachkraft vornehmen
- Die Lichtquelle in dieser Lampe sollte ausschließlich seitens des Herstellers oder seiner Servicestelle oder einer ähnlich qualifizierten Person ersetzt werden
- falls der externe flexible Kabel dieser Leuchte beschädigt ist, darf er ausschließlich vom Hersteller oder seiner Servicestelle oder einer anderen qualifizierter Person ersetzt werden, um Gefahren zu vorbeugen

RU: ПРЕДУПРЕЖДЕНИЕ:

- Светильник должен быть отделен от ванны, душевой кабины или источника разбрызгивания воды мин. 0,6м (зона 3)
- Установку, подключение и замену должен проводить специалист
- Источник света, имеющийся в этом осветительном приборе, может замениться только изготовителем, его сервисным агентом или другим подобным уполномоченным лицом
- если внешний гибкий кабель или шнур этого осветительного прибора поврежден, чтобы избежать возникновения опасности, он должен быть заменен исключительно изготовителем или его сервисным агентом или другим подобным уполномоченным лицом

FR: CAUTION:

- Il est nécessaire d'installer un éclairage à une distance de 60 cm de la baignoire, du receveur de douche ou du filet d'eau (zone 3).
- L'installation, la connexion et le changement doivent être réalisés par une personne qualifiée.
- La source de lumière émis par ce luminaire ne doit être remplacée que par le fabricant, son agent de service ou une personne dûment qualifiée
- si le flexible ou le câble externe de ce luminaire est endommagé, il ne doit être remplacé que par le fabricant, son service agréé ou une perssone similaire dûment qualifiée afin d'éviter le danger

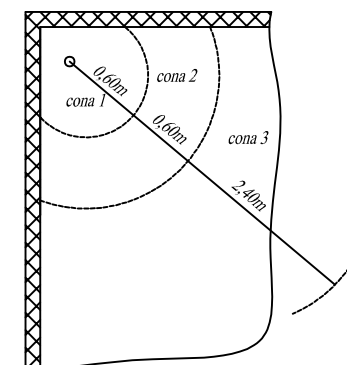
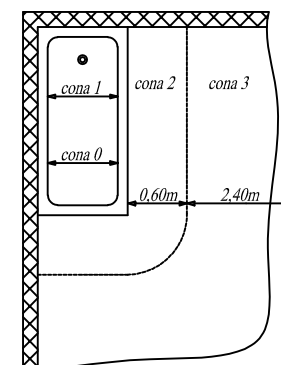
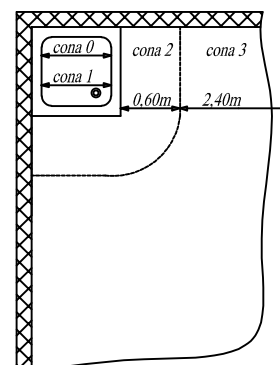

Tip: TO 70, 90, 110

1

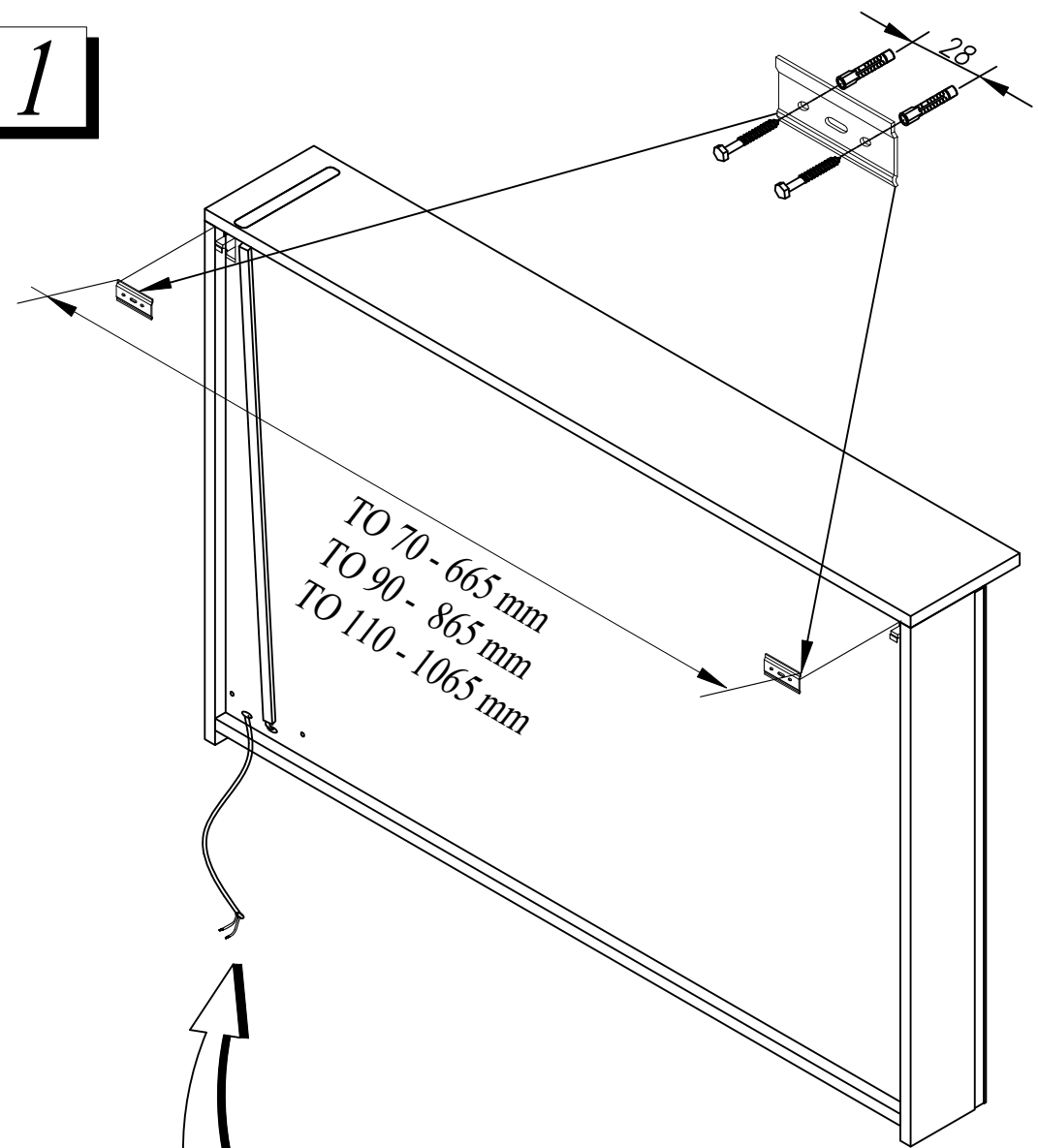

TO 70 - 665 mm
 TO 90 - 865 mm
 TO 110 - 1065 mm

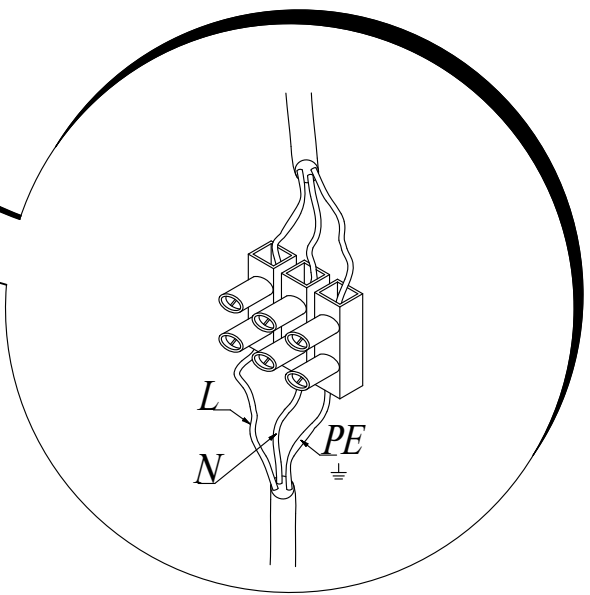



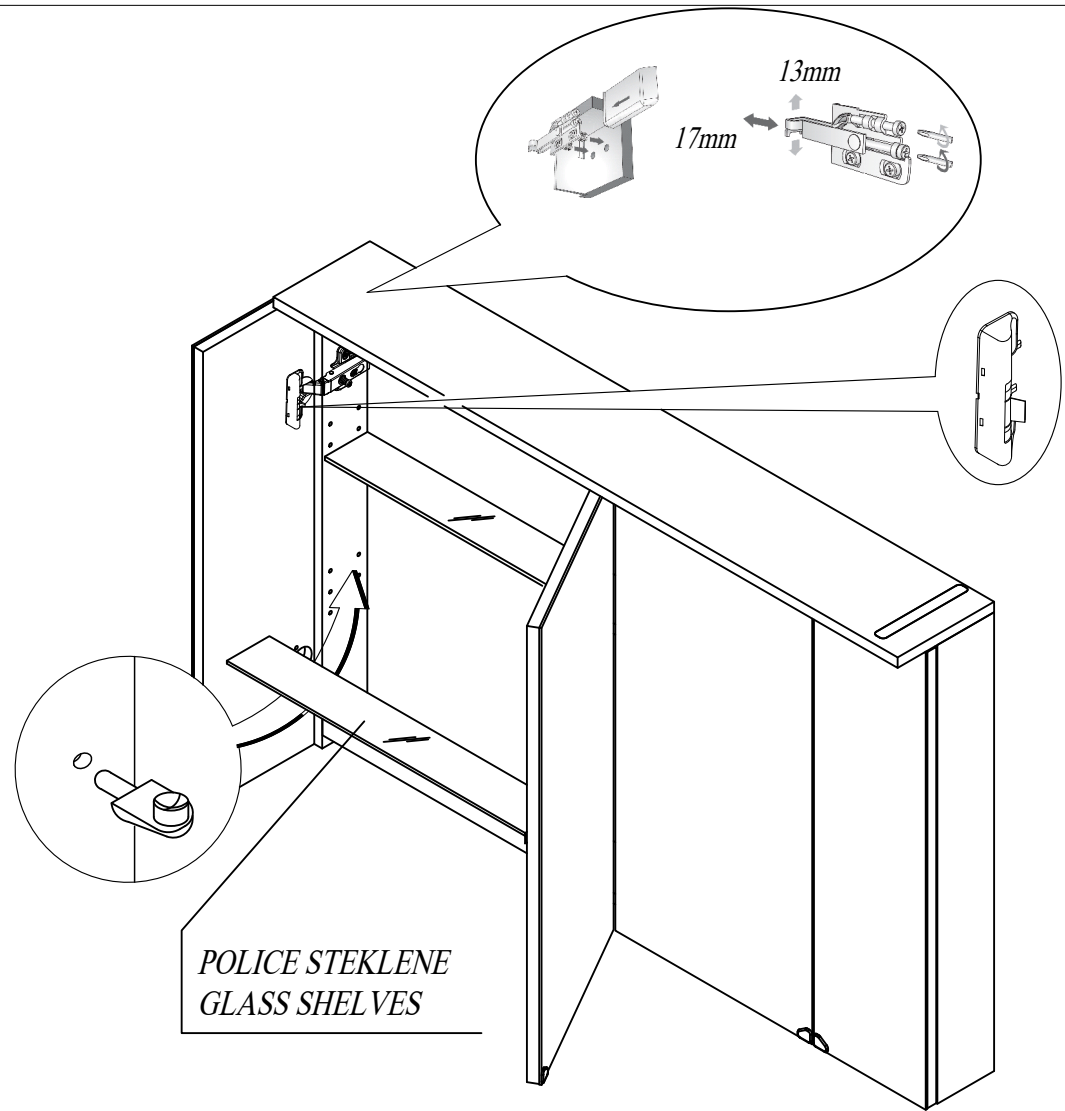

⚡ 230 V

2

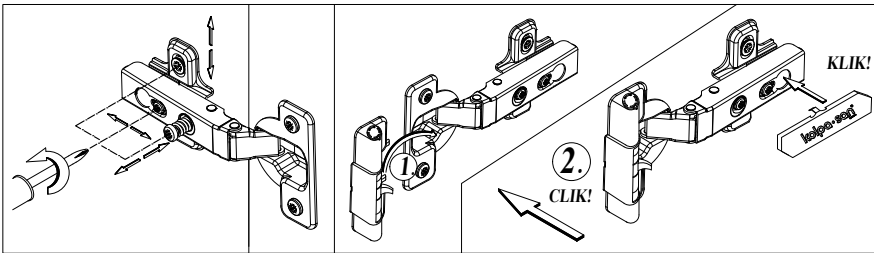
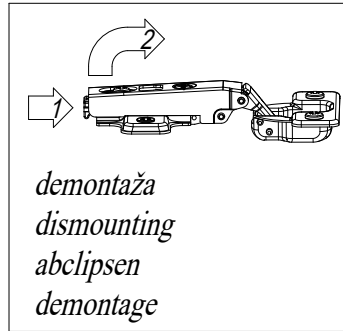
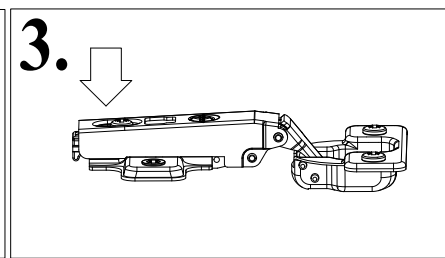
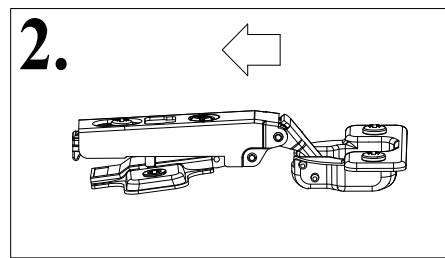
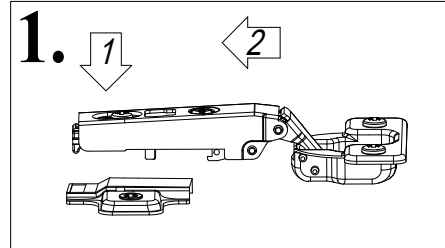

POLICE STEKLENE
 GLASS SHELVES



2x  4x  4x 

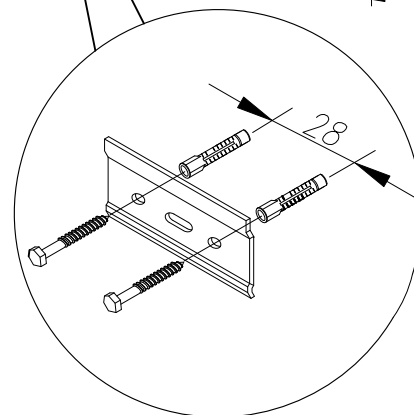
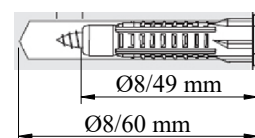
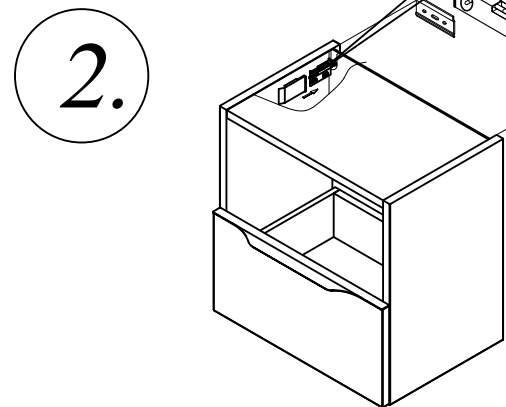
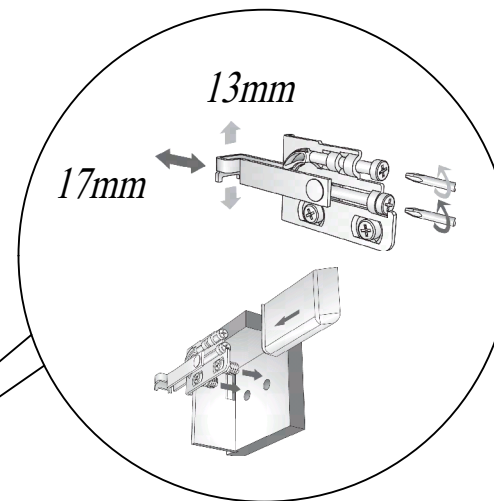
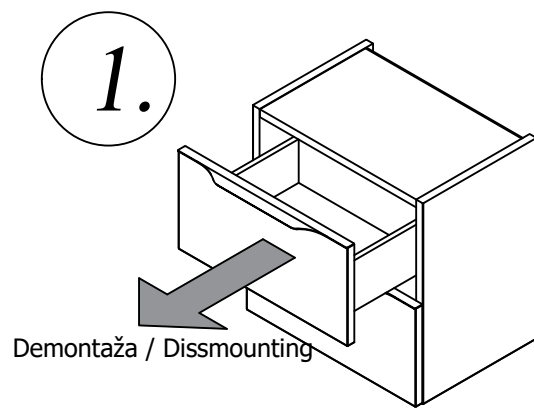

Demontaža / Dismounting

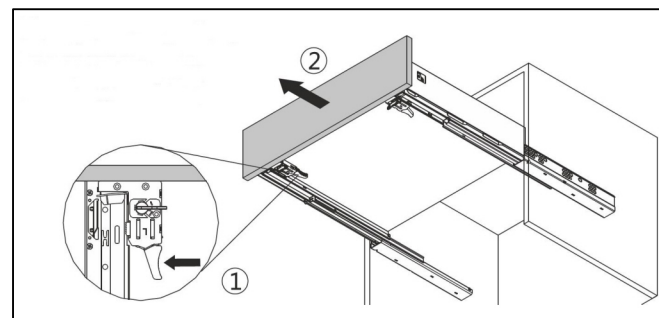

Montaža / Mounting

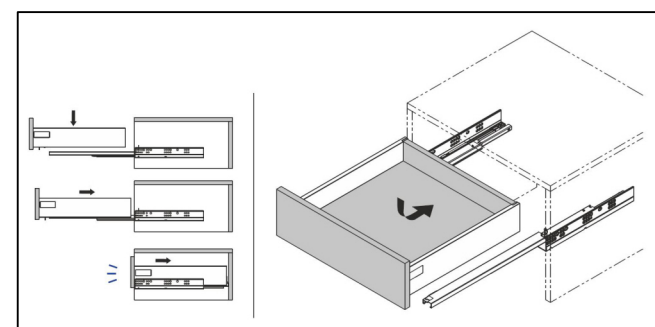

Kolpa-san
by KOLPA

- SI** Montažno navodilo
- HR** Upute za montažu
- BIH** Upute za montažu
- SRB** Uputstva za montažu
- BIH** Uputstva za montažu
- CG** Uputstva za montažu
- MK** Инструкции за монтажа
- HU** Szerelési utasítás
- GB** Assembly instructions
- DE** Einbauleitungen
- RU** Инструкция по монтажу
- FR** Instruction d'assemblage

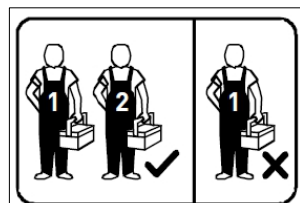
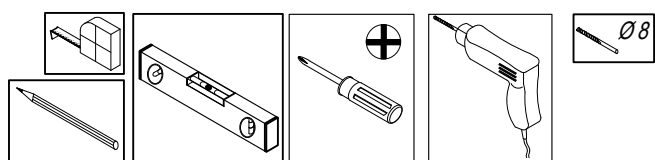
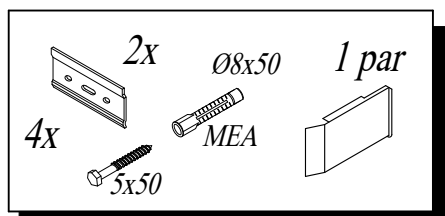
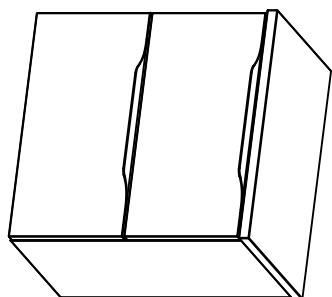

Tip: TAKA - OT 45

3.

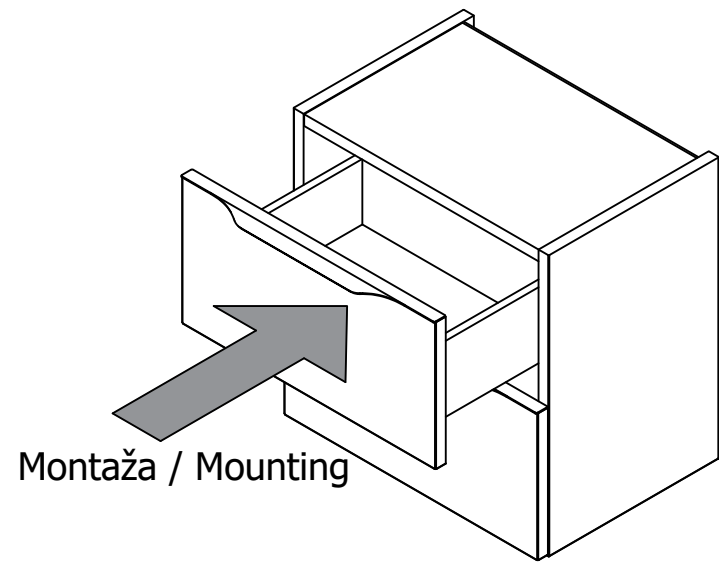

Nastavitve / Adjustment

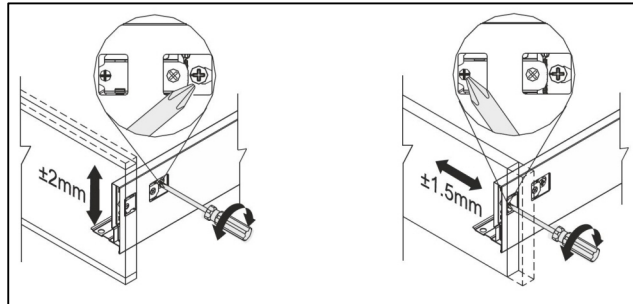

Odstranitev fronte / Removing of the front

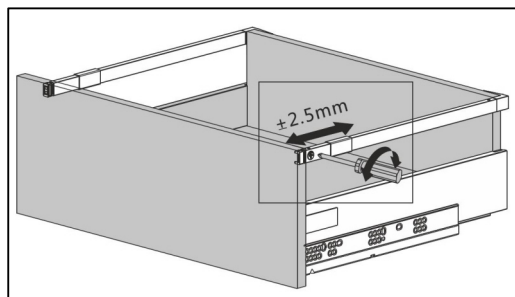
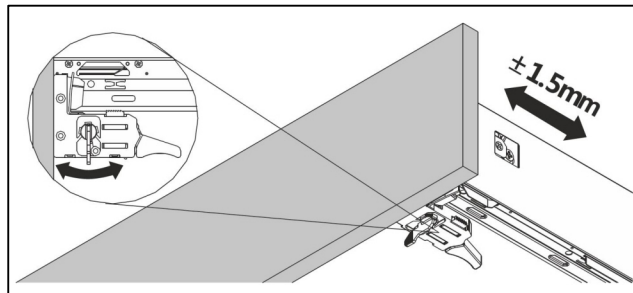
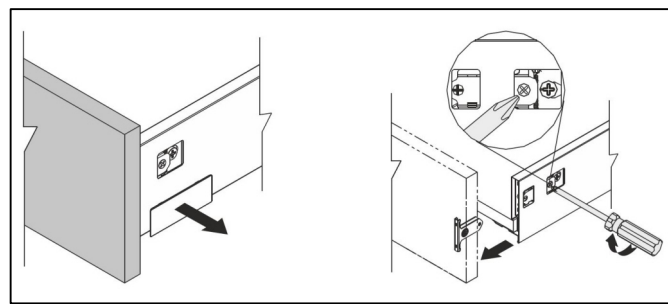

3

4.

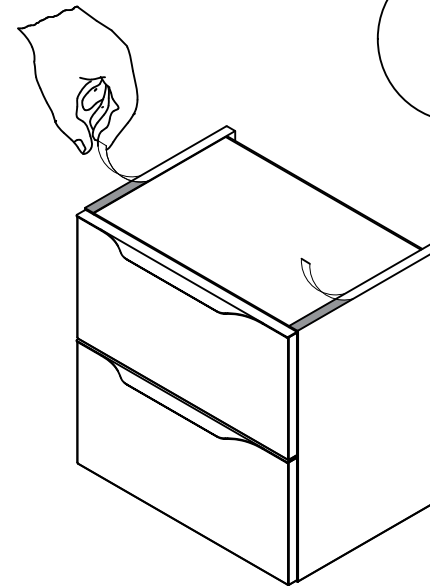

5.

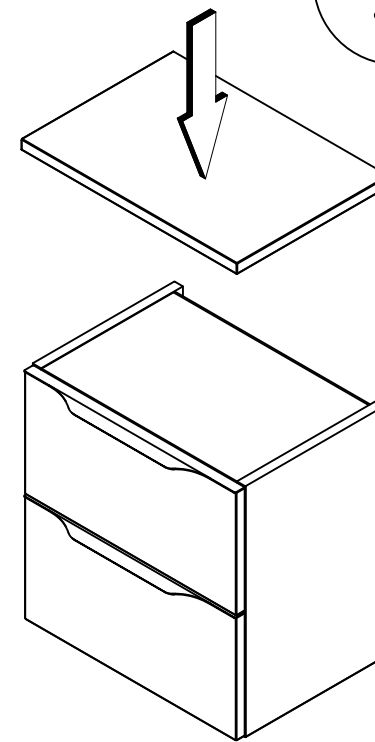

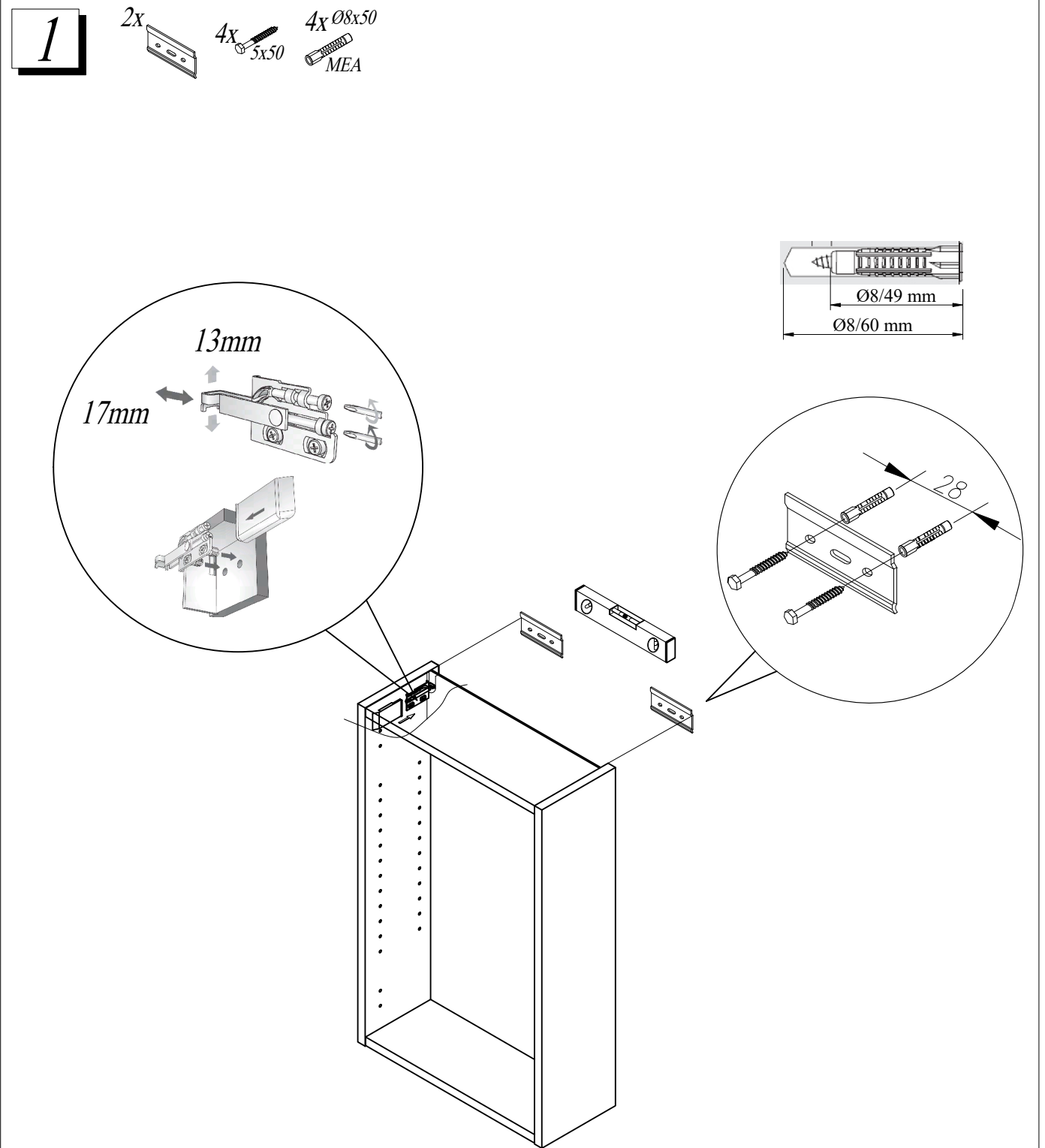

Kolpa-san
by KOLPA

- SI** Montažno navodilo
- HR** Upute za montažu
- BIH** Upute za montažu
- SRB** Uputstva za montažu
- BIH** Uputstva za montažu
- CG** Uputstva za montažu
- MK** Инструкцији за монтажа
- HU** Szerelési utasítás
- GB** Assembly instructions
- DE** Einbauanleitung
- RU** Инструкция по монтажу
- FR** Instruction d'assemblage

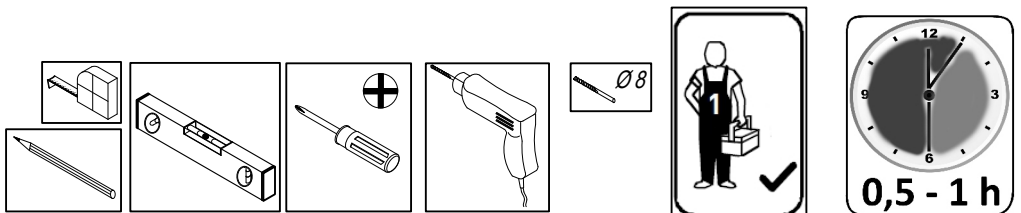
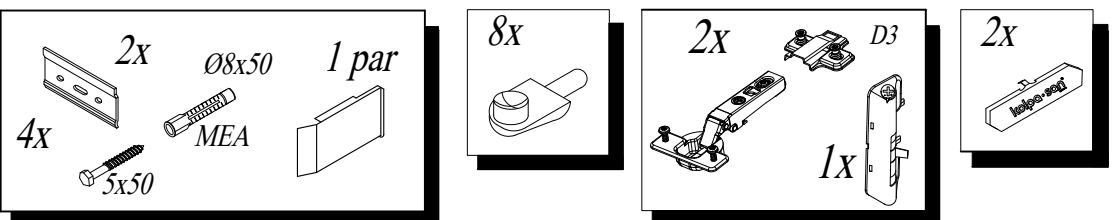
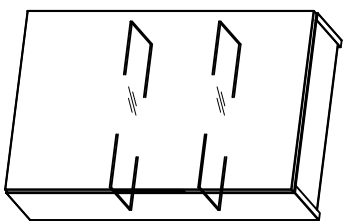

Tip: TARA / ADELE - A/T 712/20

2

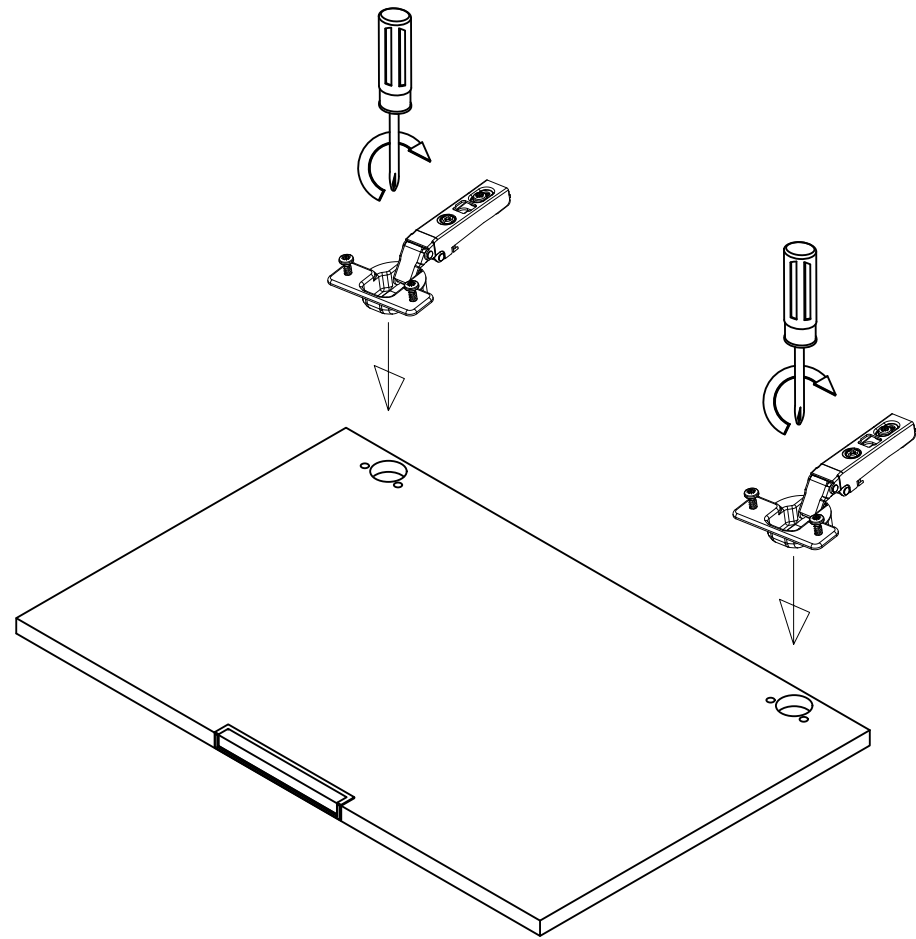
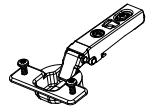

3

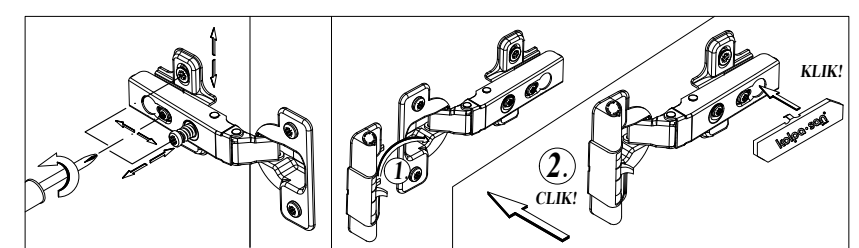
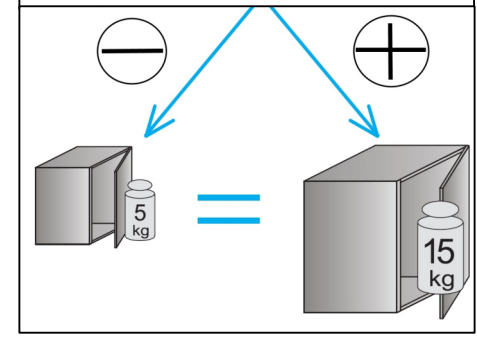
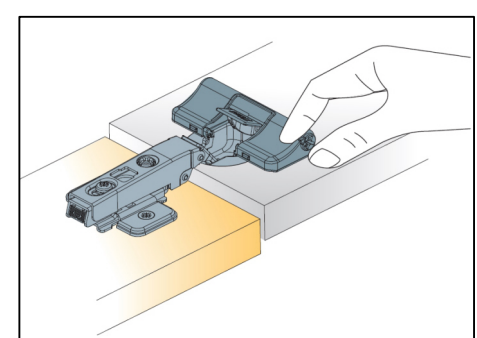
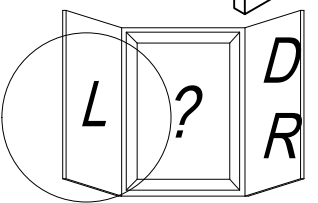
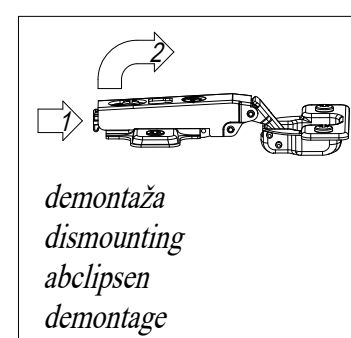
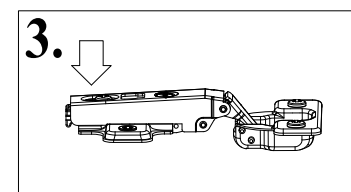
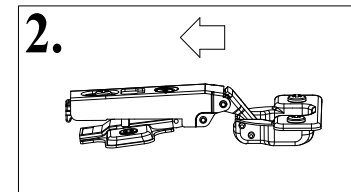
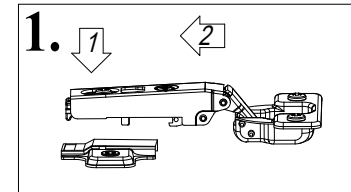
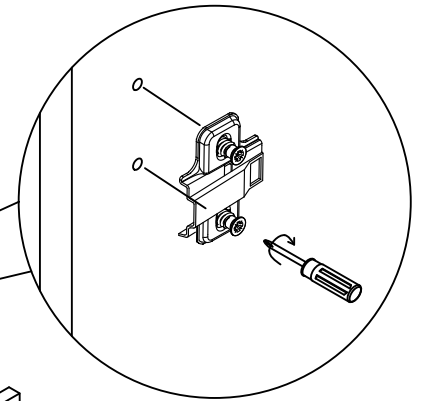
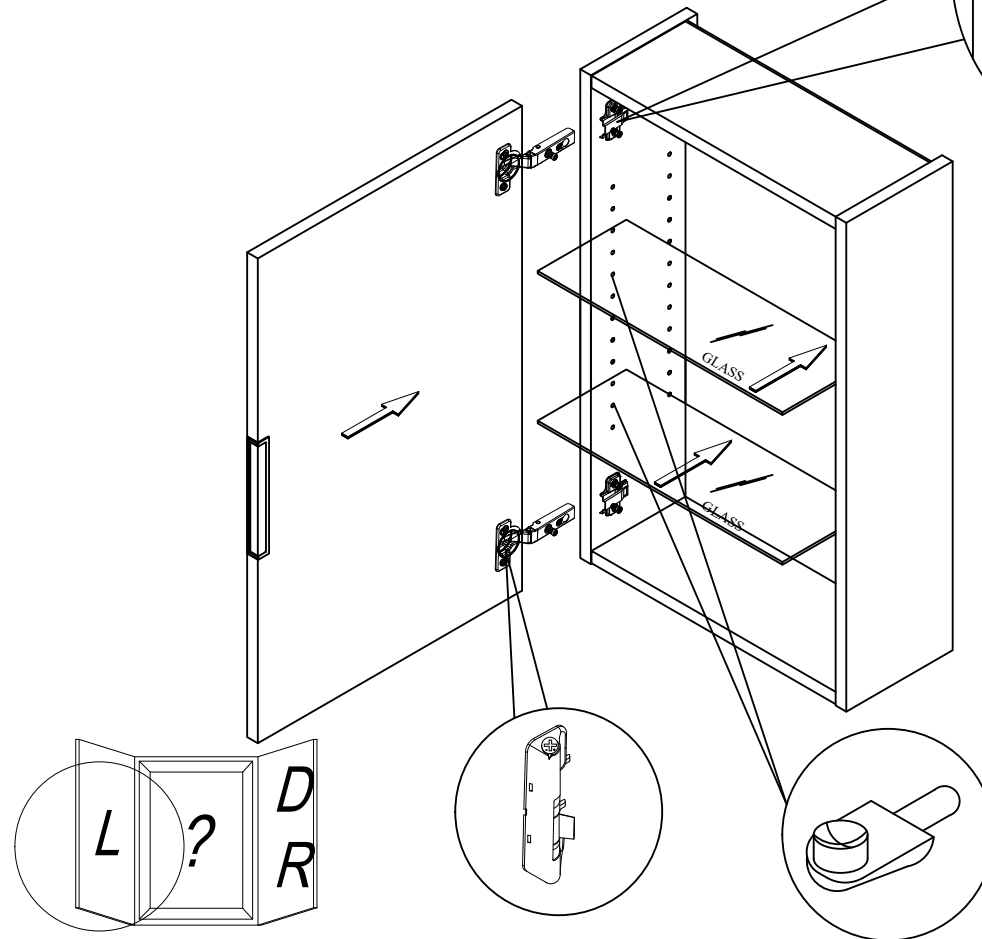
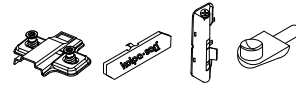

Kolpa-san®

by KOLPA

- SI** Montažno navodilo
- HR** Upute za montažu
- BIH** Upute za montažu
- SRB** Uputstva za montažu
- BIH** Uputstva za montažu
- CG** Uputstva za montažu
- MK** Инструкција за монтажа
- HU** Szerelési utasítás
- GB** Assembly instructions
- DE** Einbauleitungen
- RU** Инструкция по монтажу
- FR** Instruction d'assemblage

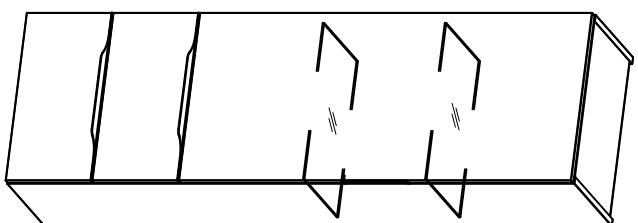

Tip: TARA - T 1501

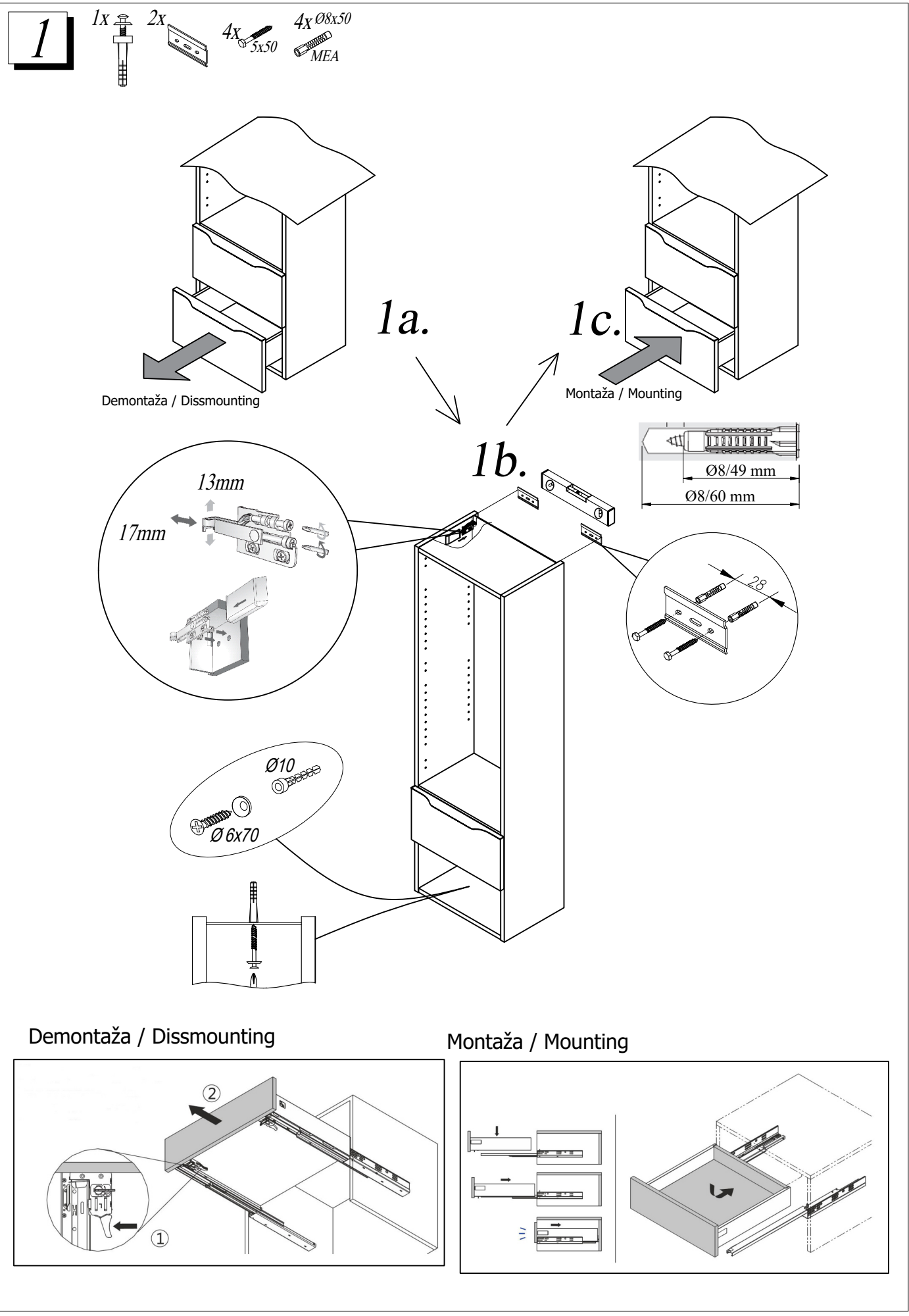
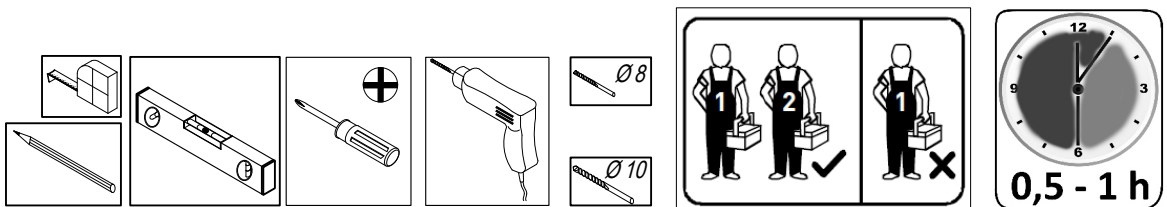
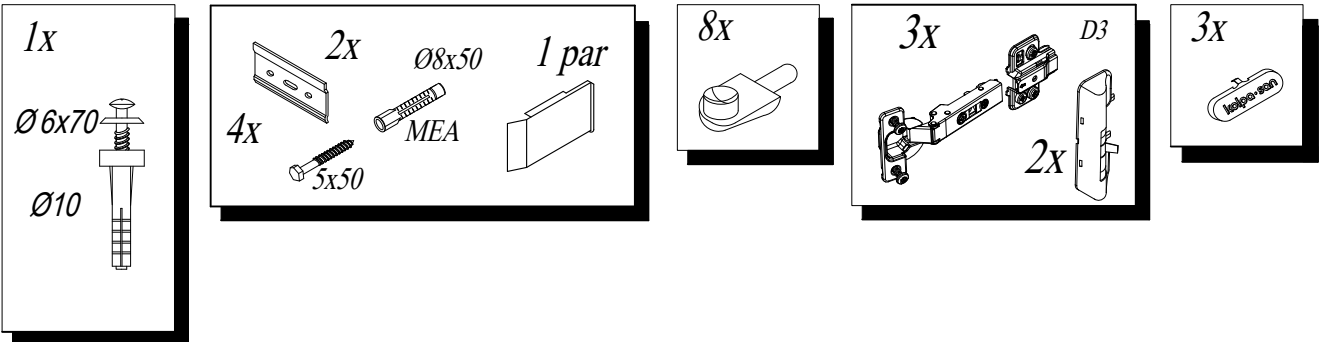

Demontaža / Dismounting

Montaža / Mounting

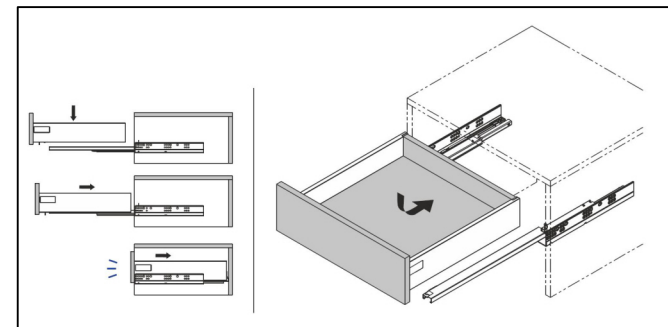
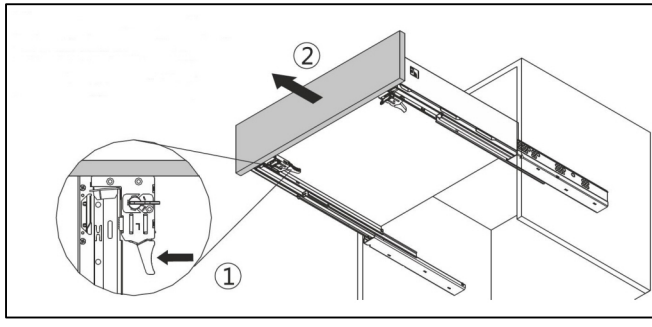

2

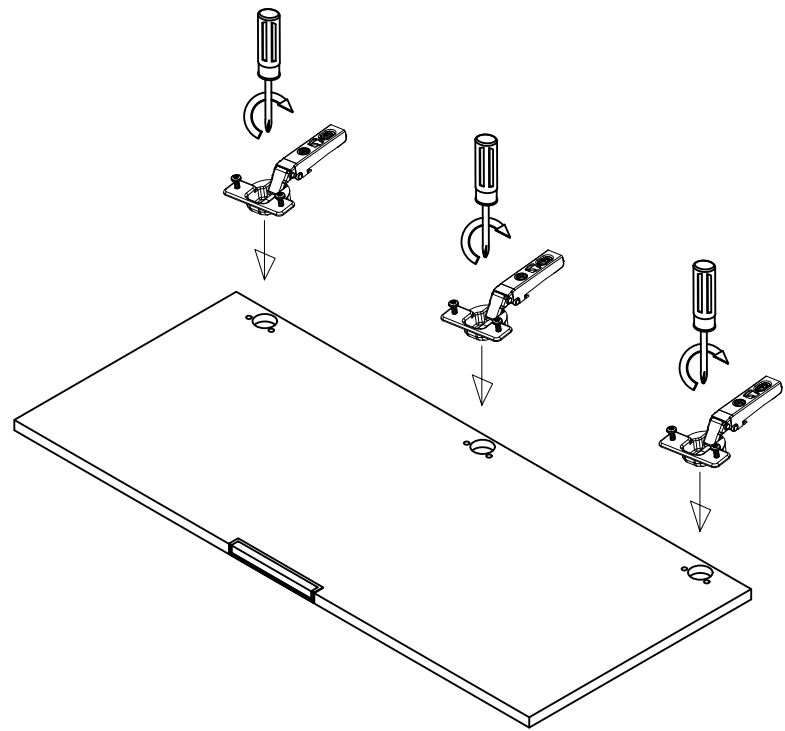
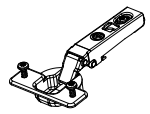

Nastavitve / Adjustment

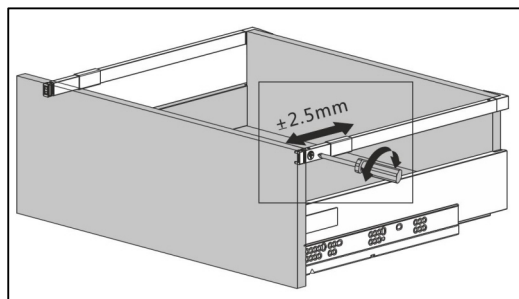
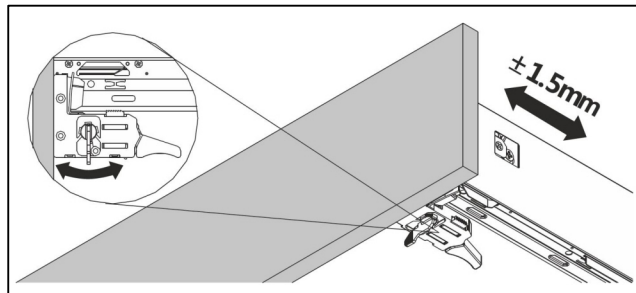
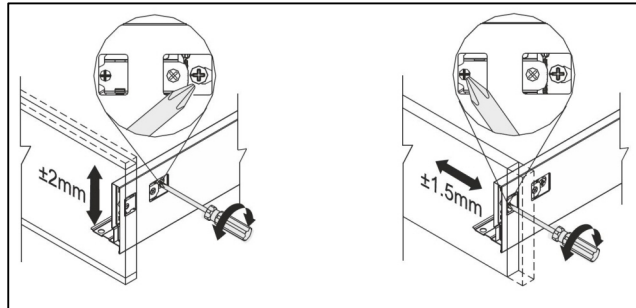

Odstranitev fronte / Removing of the front

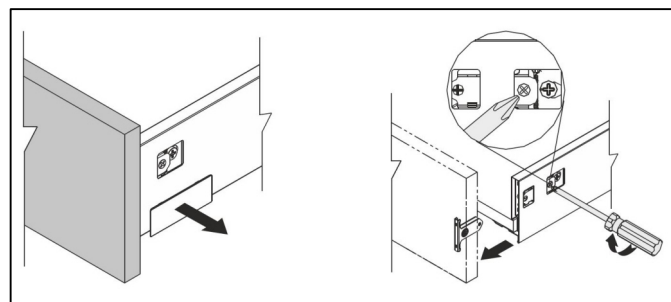

3

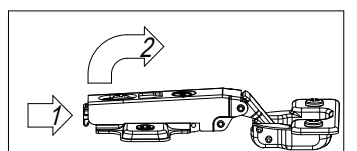
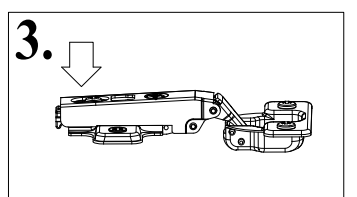
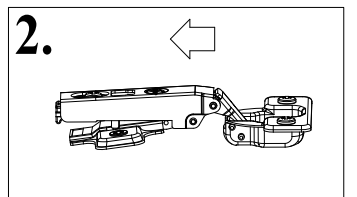
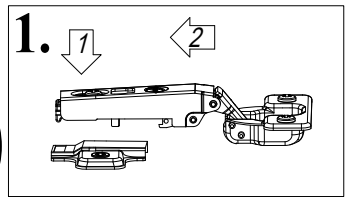
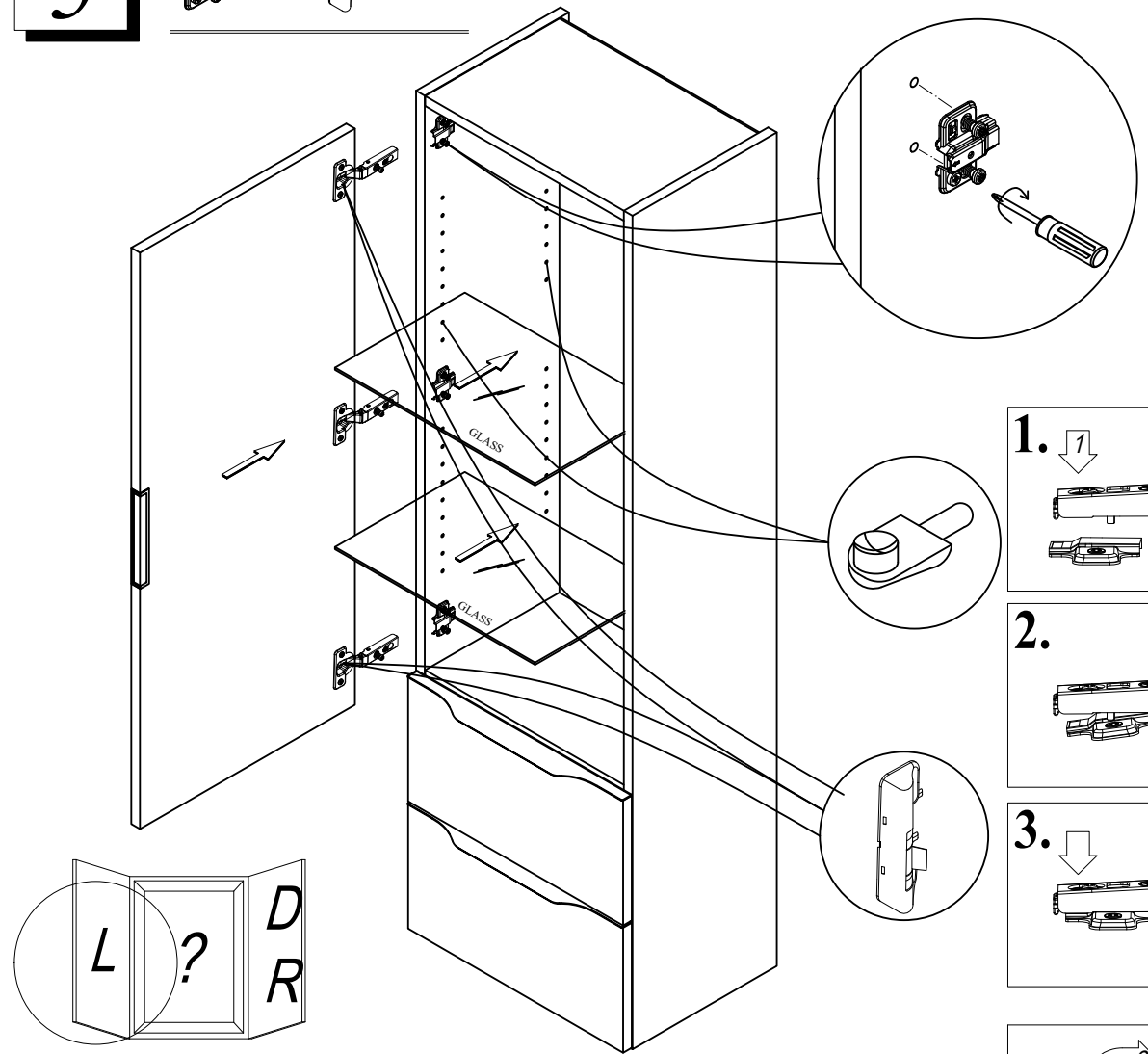
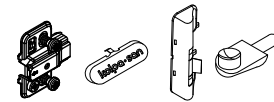

demontaža
dismounting
abclipsen
demontage

